



23 January 2025

Chris Milne

[fyi-request-29566-3bd8dede@requests.fyi.org.nz](mailto:fyi-request-29566-3bd8dede@requests.fyi.org.nz)

Dear Chris Milne

**Request for Information – Local Government Official Information and Meetings Act (the Act) 1987**

We refer to your request dated 16 December 2024 for:

*Please supply all information during 2024 about the number of Waste Management electric trucks contractually required to be utilised in rubbish and recycling collection in Lower Hutt and reports by Waste Management to Council, and reports requested by Officers to Waste Management, and reports to council committees of the number of trucks actually being used, including details of the number of trucks that are not being used due to repairs, maintenance and other issues requiring them to be off the road.*

Our Records indicate that you made two requests at different times for the same Information. This is a response to both requests. Please find attached Information within the scope of your request. Some Information has been withheld under section 7(2)(a) of the Act, to protect the privacy of natural persons.

If you are unhappy with the response to your information request, you can seek an investigation and review by the Ombudsman. Information about how to make a complaint is available at [www.ombudsman.parliament.nz](http://www.ombudsman.parliament.nz) or freephone 0800 802 602.

Please note that this response to your information request may be published on Hutt City Council's website. Please refer to the following link: [www.huttcity.govt.nz/council/contactus/make-an-official-information-act-request/proactive-releases](http://www.huttcity.govt.nz/council/contactus/make-an-official-information-act-request/proactive-releases)

Yours sincerely

Philip Rossiter

Senior Advisor, Official Information and Privacy

**From:** [Jörn Scherzer](#)  
**To:** [Sarah Whiteman](#)  
**Subject:** Re: [EXTERNAL] FW: [EXTERNAL EMAIL] Quick follow up on our lunch catch and actions for follow up

---

Let's have another catch up on the kerbside aspect pls. I can do Thu or Fri next week.

I think there are a lot of uncertainties and I don't have enough detail on the pathway other than potentially having another vehicle by the end of the year.

I don't think this can wait until the next gov meeting, and the gov meeting will be very high level so won't go into the detail that I think we need to have

Let's discuss.

**Jörn Scherzer**  
**Head of Climate and Waste**

On 4 Jul 2024, at 13:03, Sarah Whiteman <[swhiteman@wm.nz](mailto:swhiteman@wm.nz)> wrote:

No, not at this stage. Happy to have a chat.

We are absolutely committed to providing HCC with a fully electric fleet, you are across our chosen path, we always assess as we go. Perhaps we can discuss the concerns as you see them at the next Governance meeting so that the right responses are given.

Ngā Mihi | Kind regards,

Sarah Whiteman  
Regional Manager – Wellington  
WM New Zealand  
97-99 Port Road, Seaview, Lower Hutt 5010  
[REDACTED] E: [swhiteman@wm.nz](mailto:swhiteman@wm.nz)  
[www.wm.nz](http://www.wm.nz)

-----Original Message-----

From: Jörn Scherzer <[Joern.Scherzer@huttcity.govt.nz](mailto:Joern.Scherzer@huttcity.govt.nz)>  
Sent: Thursday, July 4, 2024 11:59 AM  
To: Sarah Whiteman <[swhiteman@wm.nz](mailto:swhiteman@wm.nz)>  
Subject: Re: [EXTERNAL] FW: [EXTERNAL EMAIL] Quick follow up on our lunch catch and actions for follow up

Ok, so is wmnz preparing a paper with options to the gov meeting? If so, it would be good for me to see a draft before it goes there.

Jörn Scherzer  
Head of Climate and Waste

Jörn Scherzer

Head Of Climate, Waste and Resource Recovery

Hutt City Council, 30 Laings Road, Hutt Central, Lower Hutt 5010

P: M: [REDACTED] W: [www.huttcity.govt.nz](http://www.huttcity.govt.nz) IMPORTANT: The information contained in this e-mail message may be legally privileged or confidential. The information is intended only for the recipient named in the e-mail message. If the reader of this e-mail message is not the intended recipient, you are notified that any use, copying or distribution of this e-mail message is prohibited. If you have received this e-mail message in error, please notify the sender immediately. Thank you  
On 4 Jul 2024, at 11:35, Sarah Whiteman <[swhiteman@wm.nz](mailto:swhiteman@wm.nz)> wrote:

Hi Jörn

Was with David when your email came in.

This belongs with Governance.

Ngā Mihi | Kind regards,

Sarah Whiteman  
Regional Manager – Wellington  
WM New Zealand  
97-99 Port Road, Seaview, Lower Hutt 5010  
M: [REDACTED] E: swhiteman@wm.nz  
www.wm.nz

-----Original Message-----

From: Jörn Scherzer <Joern.Scherzer@huttcity.govt.nz>  
Sent: Thursday, July 4, 2024 9:58 AM  
To: Sarah Whiteman <swhiteman@wm.nz>  
Subject: Re: [EXTERNAL] FW: [EXTERNAL EMAIL] Quick follow up on our lunch catch and actions for follow up

Thanks Sarah

Regarding electrification, I think it would be useful for WMNZ to provide some additional information on options, and some potential scenarios.

Looking at councillor feedback and ongoing questions, including at Tuesday's meeting earlier this week, I will need to provide them with further information on the timeline (what, when, options for acceleration, etc).

Scenarios could include:

1. Manor Park delayed, but operational by early 2026: vehicle roll out using the ev hub at Silverstream from March 2025, and options for a fully electric fleet by mid 2025 vs end 2025 etc
2. Manor Park delayed by a further 1-2 years: what does this mean, and does a plan B look like
3. Manor Park not going ahead at all

In light of the manor park delays and uncertainty, I think WMNZ needs to start looking at alternatives beyond manor park for truck charging. This could include temporary infrastructure, like DC chargers that are trickle charged on AC.

I would suggest it gets added to the ops agenda, with wmnz coming back on options in the first instance. The options and preferred approach could then go to the gov group in early September.

I hope this is ok, kind regards

Jörn Scherzer  
Head of Climate and Waste  
[REDACTED]

Jörn Scherzer

Head Of Climate, Waste and Resource Recovery

Hutt City Council, 30 Laings Road, Hutt Central, Lower Hutt 5010

P: M: [REDACTED] W: www.huttcity.govt.nz  
IMPORTANT: The information contained in this e-mail message may be legally privileged or confidential. The information is intended only for the recipient named in the e-mail message. If the reader of this e-mail message is not the intended recipient, you are notified that any use, copying or distribution of this e-mail message is prohibited. If you have received this e-mail message in error, please notify the sender immediately. Thank you  
On 25 Jun 2024, at 13:06, Sarah Whiteman <swhiteman@wm.nz> wrote:

Hi Jörn

Thanks for the summary below, I have added some notes in red below.

Ngā Mihi | Kind regards,

Sarah Whiteman  
Regional Manager – Wellington  
WM New Zealand  
97-99 Port Road, Seaview, Lower Hutt 5010  
M: [REDACTED] E: swhiteman@wm.nz<mailto:swhiteman@wm.nz>  
www.wm.nz<http://www.wm.nz/>

<image001.png>

---

From: Jörn Scherzer <Joern.Scherzer@huttcity.govt.nz<mailto:Joern.Scherzer@huttcity.govt.nz>>  
Sent: Thursday, June 20, 2024 4:53:53 pm  
To: Sarah Whiteman  
<SWhiteman@wastemanagement.co.nz<mailto:SWhiteman@wastemanagement.co.nz>>; Geoffrey  
Roberts <Geoffrey.Roberts@huttcity.govt.nz<mailto:Geoffrey.Roberts@huttcity.govt.nz>>; [REDACTED]  
[REDACTED]  
Subject: [EXTERNAL EMAIL] Quick follow up on our lunch catch and actions for follow up

STOP – THINK – ACT: This email is from an external source - be careful of attachments and links.  
Please follow the Cyber  
Code<<https://wastemanagementnz.sharepoint.com/sites/it/IT%20Public%20Documents/Forms/AllItems.aspx?id=%2Fsites%2Fit%2FIT%20Public%20Documents%2FWMNZ-CyberCode.jpg&parent=%2Fsites%2Fit%2FIT%20Public%20Documents>> and report suspicious emails using the “Report Message” feature in the toolbar.  
Hi team

I meant to circulate the actions coming from our lunch meeting the other day, but here goes... if I missed anything, please call out.

Confirm pricing for resource recovery opportunities at Silverstream, eg treated timber.

Update as at 20 June: [REDACTED] sent through some pricing for three potential streams, and we are discussing them internally, see attached. Pricing on treated timber yet to come. Note that we currently also looking at tyres, tbc.

Fleet electrification for kerbside: WMNZ will come back on the expected timeline asap.

Head of fleet has confirmed the first fully electric SL to be here end of 2024, this will work nicely with your charging infrastructure timeline. The rest of the fleet will fall into 2025 & 2026.

Electrification of landfill equipment, in light of the hub opening in March 2025: WMNZ will come back on the expected timeline and details in light of previous commitment to electrify some vehicles, eg loader, litter truck

At a separate discussion, [REDACTED] noted that WMNZ is developing a carbon reduction plan for Silverstream, to be completed in August.

Note from Jörn: in light of the possibly limited life of the loader at the transfer station, I would be happy for WMNZ to look at swapping that commitment out with an electric truck. Or the loader could later move to another site (eg Manor Park if that goes ahead), and it could be swapped for some other electric machinery. Of course, if both a loader and truck can be electrified that would be better. The Government is launching the truck discount scheme in August (up to \$80k per vehicle), but its first come first serve.

Noted, [REDACTED] will continue to work through opportunities and look at the loader.

Inorganic waste collection: discussed AKL’s bookable scheme, WMNZ to come back with some costings on a potential service addition in Lower Hutt

Tracy has information on our Inorganic Collection in Auckland and we will put this together in a document to circulate. Costing will be high level but you can get a feel for it.  
Let's check in again in early July...

Kind regards

J

Jörn Scherzer

(pronounce as "Yearn Shar-tza)

Head of Climate, Waste and Resource Recovery

Hutt City Council, 30 Laings Road, Private Bag 31912, Lower Hutt 5040, New Zealand M [REDACTED]

[REDACTED] W [www.huttcity.govt.nz](http://www.huttcity.govt.nz)<<http://www.huttcity.govt.nz/>>

Jörn Scherzer

Head Of Climate, Waste and Resource Recovery

Hutt City Council, 30 Laings Road, Hutt Central, Lower Hutt 5010

P: [REDACTED] W: [www.huttcity.govt.nz](http://www.huttcity.govt.nz)<<http://www.huttcity.govt.nz/>>

<image002.png>

<<http://hutt.city/renewals>>

<image003.png>

**IMPORTANT:** The information contained in this e-mail message may be legally privileged or confidential. The information is intended only for the recipient named in the e-mail message. If the reader of this e-mail message is not the intended recipient, you are notified that any use, copying or distribution of this e-mail message is prohibited. If you have received this e-mail message in error, please notify the sender immediately. Thank you

This electronic message together with any attachments is confidential. If you are not the intended recipient: (i) do not copy, disclose or use the contents in any way; (ii) please let us know by return e-mail immediately and then permanently delete the message and destroy all printed copies. Waste Management NZ Ltd is not responsible for any changes made to this message and/or any attachments after sending by Waste Management.

This electronic message together with any attachments is confidential. If you are not the intended recipient: (i) do not copy, disclose or use the contents in any way; (ii) please let us know by return e-mail immediately and then permanently delete the message and destroy all printed copies. Waste Management NZ Ltd is not responsible for any changes made to this message and/or any attachments after sending by Waste Management.

This electronic message together with any attachments is confidential. If you are not the intended recipient: (i) do not copy, disclose or use the contents in any way; (ii) please let us know by return e-mail immediately and then permanently delete the message and destroy all printed copies. Waste Management NZ Ltd is not responsible for any changes made to this message and/or any attachments after sending by Waste Management.

**From:** [Sarah Whiteman](#)  
**To:** [Geoffrey Roberts](#)  
**Cc:** [Jörn Scherzer](#); [REDACTED]  
**Subject:** [EXTERNAL] EV comment  
**Date:** Monday, 4 November 2024 9:40:14 am  
**Attachments:** [image001.png](#)  
[HCC Price Clarifications - Waste Management NZ Ltd 08.07.2020.pdf](#)

---

Hi Geoff,

Hope all is well.

I am just following up re a comment that was made about the EV's to [REDACTED] last week. Hutt City Council is not at a financial disadvantage with the EV's off the road.

I have attached the HCC price Clarifications document as part of tender negotiations.

One of the questions was:

“If you had not included EVs in your recycling fleet at the start of the contract, would there have been any difference in your price?”

No. Electric vehicles are certainly more expensive than their diesel counterpart. Thanks to our national footprint and EV Innovation Hub we have been able to offer Council the EV collection vehicles at their diesel vehicle equivalent. Application of lower specification diesel or used vehicles would have had the impact of reducing price.

I hope this clears up any confusion.

Ngā Mihi | Kind regards,

**Sarah Whiteman**

Regional Manager – Wellington

WM New Zealand

97-99 Port Road, Seaview, Lower Hutt 5010

M: [REDACTED] E: [swhiteman@wm.nz](mailto:swhiteman@wm.nz)

[www.wm.nz](http://www.wm.nz)

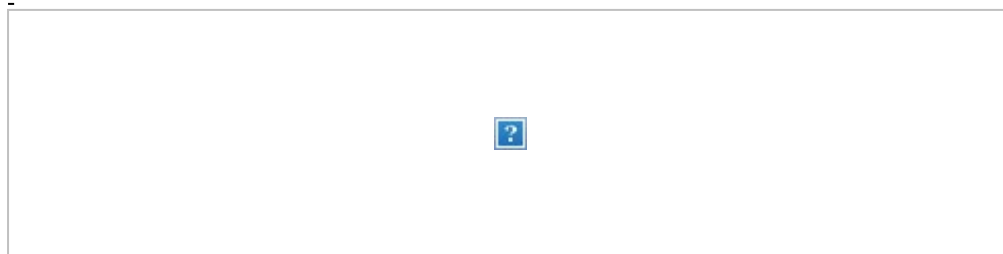

This electronic message together with any attachments is confidential. If you are not the

intended recipient: (i) do not copy, disclose or use the contents in any way; (ii) please let us know by return e-mail immediately and then permanently delete the message and destroy all printed copies. Waste Management NZ Ltd is not responsible for any changes made to this message and/or any attachments after sending by Waste Management.

**From:** [Sarah Whiteman](#)  
**To:** [Jörn Scherzer](#)  
**Subject:** [EXTERNAL] FW: Sideloader Decal area  
**Date:** Monday, 4 November 2024 12:02:01 pm  
**Attachments:** [image001.png](#)  
[Outlook-b43ga0w3](#)  
[GenV Decal Area Size SD-SL5-0001.pdf](#)

---

Further to our chat, see below and attached.

Could we get your James to work with [REDACTED]?

Ngā Mihi | Kind regards,

**Sarah Whiteman**

Regional Manager – Wellington

WM New Zealand

97-99 Port Road, Seaview, Lower Hutt 5010

M: +[REDACTED] E: [swhiteman@wm.nz](mailto:swhiteman@wm.nz)

[www.wm.nz](http://www.wm.nz)



---

**From:** [REDACTED]  
**Sent:** Monday, 4 November 2024 11:59 AM  
**To:** Sarah Whiteman <[swhiteman@wm.nz](mailto:swhiteman@wm.nz)>  
**Cc:** [REDACTED]  
**Subject:** Sideloader Decal area

Good Morning Sarah

Please find attached Decal size area, A couple of things to note:

- First truck is a 29m3 Recycling truck
- Sign Writing is for the specified area only, any other location (back of body or cab) would need Fleet approval

Please keep [REDACTED] copied in with communication, he looks after the side loaders and will be organising the signwriting.



**Kind Regards**

[REDACTED]

Senior Project Engineer | Electric Vehicles

WM New Zealand

318 East Tamaki Dr, Auckland, 2010

[REDACTED]

[REDACTED]



This electronic message together with any attachments is confidential. If you are not the intended recipient: (i) do not copy, disclose or use the contents in any way; (ii) please let us know by return e-mail immediately and then permanently delete the message and destroy all printed copies. Waste Management NZ Ltd is not responsible for any changes made to this message and/or any attachments after sending by Waste Management.

### Kerbside Collection Contract Meeting

Date:	Thursday 11 April 2024
Present:	Samjhana Khatri, Rebecca Johnston, Rebecca Thompson (HCC), [REDACTED]
Apologies:	[REDACTED]

Discussion/Outcome/Action	Who	When
<p><b><u>Action items from minutes Thursday 11 April 2024</u></b></p> <ul style="list-style-type: none"> <li>WMNZ will email HCC about the glass crates delivery and an update from Rotiform. <b>Awaiting</b></li> <li>HCC will send Zendesk report will be emailed to WMNZ. <b>Completed</b></li> <li>WMNZ &amp; HCC agree that they should ask Sarah and Jorn to have a discussion regarding EV Trucks.</li> <li>WMNZ will reach out with an update for the EV trucks. <b>Awaiting</b></li> <li>WMNZ will email through an update to HCC on the bin brackets. <b>Completed</b></li> <li>HCC will email WMNZ regarding the Power BI. <b>Awaiting</b></li> </ul>		
<p><b><u>Zendesk reporting</u></b></p> <p><b><u>Discussion:</u></b></p> <ul style="list-style-type: none"> <li>Missed collections for the month of March shows a total of 146 missed, with WM at fault being 71, the colours for this are red being 27, Yellow being 17, Green being 12 and Blue being 15. With residential fault standing at 15, the colours for this Red being 6, Yellow being 4, Green being 4 and Blue having 0. Partially empties stand at 33.</li> <li>Reporting for missing bins showed 94 and damaged bins show 103.</li> <li>WMNZ has being speaking to its drivers about kerbside repairs before it gets reported – like hinges and wheels.</li> <li>New Build showed a total of 27 with 26 being yes, we meet the KPI standing at 26 and no we did not meet KPI at 1. This shows a percentage of 96%.</li> <li>Swap showed a total of 37 with 33 being yes, we meet the KPI and 7 that we do not meet the KPI. This shows a percentage of 90%.</li> <li>Missed collection showed a total of 87 with being yes, we meet the KPI at 80 and no we did not meet the KPI standing at 8. This shows a percentage of 90%.</li> <li>The Zendesk report will be emailed to WMNZ.</li> </ul>	Samjhana	

<ul style="list-style-type: none"> <li>WMNZ discussed the fact that tickets that come in between 11-12 are trickier with KPI, HCC suggested that going forward they would hold tickets back for this hour so the KPI would be easier to meet.</li> </ul> <p><b>Outcomes:</b></p> <ul style="list-style-type: none"> <li>HCC suggested that going forward they would hold tickets back for that come in just before midday for an hour.</li> </ul> <p><b>Actions:</b></p> <ul style="list-style-type: none"> <li>HCC will send Zendesk report will be emailed to WMNZ.</li> </ul>		
<p><b>Aerosols</b></p> <p><b>Discussion:</b></p> <ul style="list-style-type: none"> <li>HCC asked the question as to why aerosols cannot be recycled. HCC stated that this was bought up at governance. WMNZ advised aerosols are considered a hazardous good – they have the label on the back declaring them as such. Oji currently do not recycle them, because they do not have a process to recycle them. Oji use rollers to sort there recycling and if a roller were to catch an aerosol it could potential explode, WMNZ state that Oji would also need a certificate showing that they can handle the dangerous good.</li> </ul> <p><b>Outcomes:</b></p> <ul style="list-style-type: none"> <li>N / A</li> </ul> <p><b>Action Point:</b></p> <ul style="list-style-type: none"> <li>N / A</li> </ul>	<p>Samjhana</p>	
<p><b>EV Trucks</b></p> <p><b>Discussion:</b></p> <ul style="list-style-type: none"> <li>HCC inquired into the contract that contractors are supposed to start kerbside collections service with EV trucks from 2024 – HCC asked if there was an update for this timeframe until we are fully electric. WMNZ state they currently have 12 EV trucks in the</li> </ul>	<p>Samjhana</p>	

<p>fleet, but they have been having issues with the EV trucks. WMNZ state that the last update was for 2024 for a side loader truck to come down, but it was held up due to CONVID and the materials need to make the vehicles.</p> <ul style="list-style-type: none"> <li>• HCC asked into if the current operation is still going to be moved, WMNZ stated that they cannot answer this at this time.</li> <li>• WMNZ &amp; HCC agree that they should ask Sarah and Jorn should have this discussion.</li> </ul> <p>• <b><u>Outcomes:</u></b></p> <ul style="list-style-type: none"> <li>• N / A</li> </ul> <p><b><u>Action Point:</u></b></p> <ul style="list-style-type: none"> <li>• WMNZ &amp; HCC agree that they should ask Sarah and Jorn as this is a governance matter of discussion.</li> <li>• WMNZ will reach out with an update for the EV trucks.</li> </ul>		
<p><b><u>Bin brackets</u></b></p> <p><b><u>Discussion:</u></b></p> <ul style="list-style-type: none"> <li>• HCC was just wanted to discuss if there is an update on the bin brackets on trucks discussed in the last meeting. WMNZ is still awaiting on the pricing for the brackets and the installation seems simple. WMNZ have been discussing even putting these bins on their rubbish trucks as well.</li> <li>• HCC is asking to see if there is any update on this, WMNZ will update and email it through.</li> </ul> <p><b><u>Outcomes:</u></b></p> <ul style="list-style-type: none"> <li>• N / A</li> </ul> <p><b><u>Action Point:</u></b></p> <ul style="list-style-type: none"> <li>• HCC is asking to see if there is any update on this, WMNZ will update and email it through.</li> </ul>	<p>Samjhana</p>	

**Health & Safety**

**Injury:**

- N / A

**Incidents:**

- Driver of an electric van has opened the door of the van, a gust of wind has caught the door and pulled it from the drivers grasp, the door does now not open/close properly.
- Driver was completing a turn at the top of a street when the truck has not been able to reverse safely without the possibility of colliding with a vehicle, the staff have found the resident of the vehicle, and the resident has agreed to move their vehicle. The vehicle owner has then driven their car forward and has collided with the truck, causing minor damage to the truck and some damage to the vehicle.
- Driver was trying to get through two parked cars and has got to close to one of them causing a scrap down the side and minor damage to the rear bumper of the car.
- Driver was closing the back door of the truck not realising he had left the safety prop out at the back door so as the door came down it has bent the safety prop.
- Driver of Sideload has emptied a bin and moved off to the next bin, his side arm has struck the rear of a white van, causing it to move forward into another cars tow bar causing damage to both front and rear.
- Driver has changed from reverse to drive to reposition the vehicle in a tight lane. The truck has rolled back twice before drive has engaged. the right-hand mirror has impacted a tree branch, damaging it.
- Driver was Parked at the tip face about to unload the rubbish from the truck when a loader at the tip face was backing back and has not seen the truck parked and about to unload, the rear of the compactor and has hit the side of the truck.
- Driver of the loader. Driver has checked for damage and spoken to their manager.



<p><b>General</b></p> <ul style="list-style-type: none"> <li>• HCC inquired into if there is an update for the material used for the glass crates. WMNZ has no update from Rotiform at this moment, but there has been a stocktake taken for the glass crates which shows an order for glass crates is needed soon, so a decision must be made. The stocktake showed that they have about 1400 glass crates total with 850 already being damaged. WMNZ will email HCC about the glass crates delivery and an update from Rotiform on new material or bins.</li> <li>• HCC will email WMNZ to discuss power BI as the person involved was not present.</li> <li>• HCC stated that they have been hearing positive feedback on the green stickers from residents.</li> <li>• HCC has also noticed some positive feedback on the double bin latches in high wind zone areas.</li> </ul>		
--	--	--

Next contract meeting	9 May 2024, 1pm
-----------------------	-----------------

### Kerbside Collection Contract Meeting

Date:	Tuesday 20 <sup>th</sup> August 2024
Present:	Samjhana Khatri, Rebecca Johnston, Rebecca Thompson (HCC), [REDACTED]
Apologies:	

• Discussion/Outcome/Action	Who	When																									
<p><b><u>Action items from minutes Tuesday 20<sup>th</sup> August 2024</u></b></p> <ul style="list-style-type: none"> <li>HCC will send through screenshots of the problems being seen on Power BI</li> <li>HCC will send through a list of people who wish to have access to Power BI- <b>completed</b></li> <li>HCC will send through July report to WMNZ to review. - <b>Completed</b></li> <li>WMNZ will place a current order of 250 new 120L.- <b>Awaiting</b></li> <li>WMNZ will give Rebecca J access to their online portal for her phone.</li> <li>WMNZ will be sending through some photos for new photo ID's. - <b>Awaiting</b></li> </ul>																											
<p><b><u>Zendesk reporting</u></b></p> <p><b><u>Discussion:</u></b></p> <ul style="list-style-type: none"> <li>HCC only had the report to present for July and they will send through this report to both [REDACTED] to review.</li> <li>A note was made by HCC that reports are given a 4-day leniency for KPI when it comes to when the ticket was actioned to when the ticket is solved.</li> </ul> <table border="1"> <thead> <tr> <th>Missed Collections</th> <th></th> <th>Total of WMNZ &amp; Partially emptied</th> <th>Total</th> <th>Percentage</th> </tr> </thead> <tbody> <tr> <td>WMNZ</td> <td>62</td> <td></td> <td>88</td> <td></td> </tr> <tr> <td>Partially Emptied</td> <td>26</td> <td>Achieved</td> <td>86</td> <td>98%</td> </tr> <tr> <td>BNO</td> <td>31</td> <td>Not achieved</td> <td>2</td> <td>2%</td> </tr> <tr> <td>Other – Road works, wrong week etc</td> <td>38</td> <td></td> <td></td> <td></td> </tr> </tbody> </table>	Missed Collections		Total of WMNZ & Partially emptied	Total	Percentage	WMNZ	62		88		Partially Emptied	26	Achieved	86	98%	BNO	31	Not achieved	2	2%	Other – Road works, wrong week etc	38				Samjhana	
Missed Collections		Total of WMNZ & Partially emptied	Total	Percentage																							
WMNZ	62		88																								
Partially Emptied	26	Achieved	86	98%																							
BNO	31	Not achieved	2	2%																							
Other – Road works, wrong week etc	38																										

157			
-----	--	--	--

New Build			Total	Percentage
TOTAL	28	Achieved	28	100%

Swap			Total	Percentage
TOTAL	38		38	
		Achieved	37	97%
		Not achieved	1	3%

Green Waste			Total	Percentage
TOTAL	29		29	
		Achieved	29	96.6%
		Not achieved	1	3.6%

Damaged Bins	TOTAL	Damage Type	TOTAL
CRATE	19	MAIN BODY	10
GREEN WASTE	1	HINGES	11
RUBBISH - RED	63	WHEELS	13
RECYCLING – YELLOW	7	LIDS	46

Missing Bins	TOTAL
Bins	80
Crates	33

**Outcomes:**

- N/A

**Actions:**

- HCC will send through the July report though to WMNZ to review.



### Bin numbers & New Order

#### Discussion:

- WMNZ presented numbers for the stock of the bins in the yard, the shown figures are going to be slightly different from what was previously shown due to some bins being found and bins being miscounted. At the moment it is showing that there are 144 new 120L. When Rotiform was contacted to see if they had any 120L in stock that they had a large number of 120L stock located in Auckland, so an order might need to be made.
- Due to the large number of old bins being stored, the multiple locations there stored and due to the limited space that they have, the suggest potential using the old bins to also supply the new builds. HCC asked if we could give back excess stock of old bins back to Rotiform and WMNZ stated that they would not want them back because they have already been branded with the HCC logo.
- HCC just wanted it noted that there will be an influx of downsizing of bins in May to June 2025, due to the large number of people who received their rates for this year and saw the amount they were paying for the bin. We let the residents know that any changes will not be shown until 1<sup>st</sup> July next year, which has led to people wanting to wait till then to make the change. HCC just want to be mindful about the amount of 120L in stock.
- HCC is already looking at a large number of MUDs that will be coming through – Rebecca J is currently working on 186 of them that she is currently working on. So will also be mindful of this as well.
- HCC also just wanted to touch base on if they have some 660L sourced, due to the large number of MUDS. HCC knows that 660L are easier for WMNZ teams, due to the fact they don't have to worry about multiple individual bins. WMNZ has stated that Shane is aware of the potential high request for 660L, and they have some in stock.
- HCC just to confirm that swaps, missing, damaged bins are all supplied from old bins. HCC also gave the green light to supply new builds with old bins if the bins are good enough condition to be supplied to the residents.
- WMNZ will order some new 120L, around 250 so there is just under 400 in stock and will touch base closer to the end of the year regarding ordering new bins for next year.

#### Outcomes:

- HCC also gave the green light to use old bins to supply for new builds, if the bins are in good condition.

#### Actions:

- WMNZ will place a current order of 250 new 120L.

█ & Rebecca  
J

<p><b><u>Contaminated recycle bin &amp; Bin brackets.</u></b></p> <p><b><u>Discussion:</u></b></p> <ul style="list-style-type: none"> <li>• While doing some bin visits, Rebecca J had noticed that a bin on Whites Line West had been logged in wrong. They had a 240L, but it was recorded as a 120L, and bin numbers were also all mixed up. WMNZ stated that this was done by staff that are no longer on board.</li> <li>• Rebecca J also noticed that there were some bins that had a first red sticker that were being stickered, the resident had figured out the schedule to get there recycling bin emptied.</li> <li>• Rebecca J asked about some bins she had seen contamination for on Waddington Drive and on Newcombe Street, what had happened to them. WMNZ stated that Waddington had been given a red sticker and Newcombe had been collected.</li> <li>• WMNZ asked if Rebecca J had stickers, which Rebecca J said she did not. WMNZ stated that she should have red stickers for bins she sees contaminated and that they would give them access to the WMNZ portal on her phone so she can note the stickers she has given.</li> <li>• HCC would like an update on the bin brackets. WMNZ stated that two trucks had been fitted and the third will be installed on the Friday 23<sup>rd</sup>. They had been waiting on a pin for the bracket, but the brackets had been a nightmare. The first problem was trying to get them engineered and then they arrived with no instructions, while fleet line was busy integrating new vehicles.</li> <li>• WMNZ have said that there plans for the brackets going forward is targeting the bins of addresses who are putting there bins out later. The drivers will be given a couple of bins to do a day and any bin they find with contamination those bins can be removed. HCC have stated this will also be bins that have been bin not out over the 6 weeks.</li> <li>• HCC have confirmed that anything with hazardous items like needles should be removed automatically.</li> </ul> <p><b><u>Outcomes:</u></b></p> <ul style="list-style-type: none"> <li>• N/A</li> </ul> <p><b><u>Actions:</u></b></p> <ul style="list-style-type: none"> <li>• WMNZ will give Rebecca J access to their online portal for her phone.</li> </ul>	<p>Rebecca J &amp; Samjhana</p>	

<p><b><u>Health &amp; Safety</u></b></p> <p><b>Injuries:</b></p> <ul style="list-style-type: none"> <li>No Injuries presented for June or July.</li> </ul> <p><b>June Incidents:</b></p> <ul style="list-style-type: none"> <li>While parking in the yard one of the truck drivers had reversed into a parked vehicle causing some damage to a wing mirror.</li> <li>There had been an incident of threatening behaviour in Petone. After the reviewing the footage a couple of times they worked out the reason why the woman was so upset. [REDACTED] had ever so slightly pulled out while she was coming past, the driver then got out of her vehicle and lost her rag and then she tried to cut of the truck, trying to get the driver to crash into her.</li> </ul> <p><b>July Incidents:</b></p> <ul style="list-style-type: none"> <li>The arm had not been stowed correctly and it has caused some damage to a third parties' bumper. The driver had only been out alone for a week and a half after training, but they have been doing a good job.</li> <li>There was a wing mirror damaged on Waiwhetu Crescent, this has already been sorted with the third party.</li> <li>Another arm was damaged on Eastview Road. The arm got caught on the brow of the driveway, the driver had not realised it was caught and reversed, causing damage to the arm and a scrape across the driveway.</li> </ul>	<p>[REDACTED]</p>	
<p><b><u>General</u></b></p> <p><b>Power BI</b></p> <ul style="list-style-type: none"> <li>HCC has been having problems accessing Power BI, they are also having teammates asking for access. WMNZ had already heard from Gaynor about accessing Power BI and have already asked their services desk about sorting out access.</li> <li>WMNZ asked if HCC have valid Power BI licenses – which HCC was unsure if they had current licenses. Rebecca J can currently access the home screen but cannot click on any of the panels. She did have previous access and is unsure why she currently cannot access it.</li> <li>Samjhana does have access but has been having problems utilising the search function when it comes to specific addresses.</li> <li>Samjhana will take screenshots of the current issues she has been having and send them to [REDACTED] so she can see what is happening. WMNZ will need to see how many more than can give access to, before they hit their limit of users, but if HCC can provide a list of who is needing access to Power BI.</li> </ul>		

**Damaged bins**

- HCC was just wanting to see if there is anything that can be done regarding the large number of lids damaged that had been recorded. WMNZ stated that there really is no real set issue when it comes to lid damage, so there is really nothing that can be actioned. Lid damage can happen from a handling error from the residents or from their collection team, it also could be from repetitive use of the lid opening and closing that eventually weakens the hinges on the bins.
- HCC had seen that they are not always charged for bins and was wondering how this decision is made. WMNZ stated they are realistic when it comes to it, as per the contract there is a management fee which covers things like lids and hinges. When looking into damaged bins and they cannot get clear footage on the how the bin was damaged, they will take it as they have damaged the bin and put them on the non-charge to HCC.
- HCC inquired into seeing if there can be a warranty claim regarding the main body damage to the bins, due to them having a 10-year warranty. WMNZ explained that there is no way they can claim for a damaged main body due to the damage being an operational error either by the resident or WMNZ and that they cannot claim for damage that is not a manufacturing error.
- WMNZ have been discussing with Rotiform about the issues that have been shown on the glass crates, as they believe they can do a warranty claim on the 960 glass crates, due to all the issues that could be caused by manufacturing.

**Missing bins**

- HCC inquire into the number of missing crates found in the July report and how we can lower the number. WMNZ that missing crates are a variable that cannot be reduced due to the fact there is no real way to fix it, unless we had residents immediately place crates away after collection.
- WMNZ asked if people are charged for missing bins, which HCC confirmed that there is no charge for replacing bins. WMNZ suggest that it may need to be a option that there is a service fee for replacing missing bins, people tend to look harder to find the bin rather than pay a fee to get a new bin. WMNZ state this could be an idea that could be passed onto council to help reduce the number of missing bins recorded.

**Contamination team / Team changes**

- WMNZ just had some staff updates to share:
  - [REDACTED] has left and a new staff member [REDACTED] has been helping [REDACTED] with things.
  - [REDACTED] are no longer working with the team.
  - They have a new inspector, [REDACTED] who is working well.
  - They also have some temps that they are looking to make permanent.
- They have been fully staffed but have had some staff changes. They will need to look into getting some new ID's made and will be looking at sending through photos for them to be made.

<ul style="list-style-type: none"> <li>HCC asked about how the front facing cameras are going, WMNZ stated that they no longer use them as the team did not like wearing them. The inspection team felt that they were causing problems with intimidation, due to them strapped on there chest and the first thing you see.</li> </ul> <p><b>EV Vehicles</b></p> <ul style="list-style-type: none"> <li>HCC were just wanting an update on the vehicles for Jorn and Geoff. WMNZ last action for the vehicles was for the specs for the charging station at Silverstream. WMNZ has stated that Sarah will be getting in touch with Jorn to discuss the EV vehicles.</li> </ul>		
--	--	--

Next contract meeting	17 September 2024, 1pm
-----------------------	------------------------

# MEMORANDUM

**To** R&R Kerbside Governance Group (Jo Miller, HCC; Alison Geddes, HCC; Sarah Whiteman, WMNZ; [REDACTED])

**Cc** Geoffrey Roberts

**From** Jörn Scherzer, Head of Climate & Waste

**Date** 19 September 2024

**Subject** Update on R&R kerbside collection workstreams

## 1. PURPOSE

This memo provides an update on the performance of the Rubbish and Recycling (R&R) kerbside collection service, and the work under way to further improve service delivery.

## 2. PERFORMANCE DASHBOARD

HCC has in place a dashboard, attached as Appendix 1, to provide an overview of the performance of the service. It comprises a range of key indicators that show the results and performance of the service for the following:

- Service outcomes (recycling and green waste volumes collected)
- Recycling contamination (city-wide contamination, number of bin inspections conducted, stickers issued, bins withdrawn and bin inspection findings)
- Health and safety (injuries, incidents, near misses)
- Service performance (missed collections, bin swaps and deliveries, escalations)

Where relevant, the dashboard includes brief commentary on the insights gained, and traffic lights are used to indicate whether service performance is in line with expectations.

## 3. WORKSTREAM UPDATE

The below update provides an overview of various initiatives and workstreams under way in relation to the R&R kerbside service. Traffic light colours are used to indicate whether work is on track or behind schedule. Where applicable, related initiatives are included to update the Governance Group on the direction Hutt City Council is taking on waste collections, processing, and disposal with a long-term view of 2-3 years.

Item	Status	Description
Electrification of trucks	Delayed	<ul style="list-style-type: none"> <li>As at September 2024, 50% of vehicles have been electrified, with no change in the number of electric trucks since the end of the first year.</li> <li>WMNZ's contract (eg s33.7 of the recycling contract's Specifications) requires full electrification of the truck fleet dedicated to Council's kerbside service by 1 July 2024.</li> <li>WMNZ notes that the implementation of this was dependent on WMNZ completing its new Manor Park site, which is designed for sufficient truck charging, but the consent process for that initiative had stalled due to NZTA concerns regarding access to the site. It is understood that these concerns may soon be resolved, and the consent may continue to be processed. However, it is possible that the consent may require public notification, and there is no assurance that it will be approved.</li> <li>HCC is constructing a Heavy EV Charging Hub at Silverstream Landfill, to be completed by March 2025 (see associated item in the landfill governance memo). This could be used as a temporary alternative for charging vehicles for WMNZ once complete. However, WMNZ will need to update its EV Implementation Strategy and provide further details on the vehicles to be changed to EV over the coming 6-12 months.</li> <li>Note that Councillors have repeatedly asked questions on the progress of implementing this initiative; hence there is increasing political focus on when this will be completed.</li> </ul>
Reducing contamination and behaviour change	Under way	<ul style="list-style-type: none"> <li>As previously reported, the behaviour change campaign has resulted in an initial reduction in contamination following the implementation of our three-pronged campaign (marketing campaign, bin inspections &amp; immediate user feedback, bin removals). However, while efforts to reduce contamination continue, contamination is still 'sticky' within a range of 12-16%, refer Appendix 1 Dashboard.</li> <li>In response to a request from Council, officers provided a full report back on 'opportunities to reduce recycling contamination' to the Climate Change and Sustainability Committee on 4 September 2024 (<a href="#">see Report no: CCASC2024/4/242, page 7</a>).</li> <li>Four options were identified as offering the highest opportunity value: <ul style="list-style-type: none"> <li>(a) Bin audits before actioning a down-size request;</li> <li>(b) RFIDs and suspension of service;</li> <li>(c) Mandatory bin size increase in response to repeated contamination and/or overfull rubbish bins; and</li> <li>(d) Artificial intelligence and real time tracking</li> </ul> </li> <li>The committee endorsed these four options, and asked officers to investigate these in more detail. The committee also requested that officers look into the potential of more direct engagement with residents, to assist them in changing behaviour. HCC is now working with WMNZ to progress the above initiatives.</li> </ul>
Bin brackets on trucks	Complete	<ul style="list-style-type: none"> <li>Earlier this year, in the context of households repeatedly contaminating their recycling, it was identified that bin ambassadors are sometimes unable to issue a third strike despite various repeat visits. This could be due to residents wheeling out their bins at the last minute for collection, which means bin ambassadors are unable to inspect bins or issue a 'third strike'.</li> <li>In response, HCC worked with WMNZ on a variation to the bin removal process, whereby the drivers of collection vehicles can also inspect and remove selected bins, rather than relying purely on bin ambassadors to do so. This involved the installation of brackets on trucks (so that bins can be transported back to base), and this project was completed in August 2024.</li> </ul>
Multi-unit dwellings (MUDs) with communal waste storage	Complete	<ul style="list-style-type: none"> <li>A project was conducted last year to ensure the rightsizing of R&amp;R capacity at all MUDs with communal waste storage, to reduce unnecessary costs.</li> <li>The review of MUD sites was completed earlier, albeit an update to MUD guidance documentation was still outstanding. This was completed in June 2024, and the documents are available online. It includes a <a href="#">developer guide</a> and <a href="#">guide for residents</a>.</li> </ul>

Item	Status	Description																
Resident's Satisfaction Survey	Complete	<ul style="list-style-type: none"> <li>Council carries out annual resident satisfaction surveys for various services it provides. The results for 2024 are now available, and they continue to improve compared to 2022 and 2023.</li> </ul> <table border="1"> <thead> <tr> <th>General Waste</th> <th>Mixed recycling</th> <th>Glass</th> <th>Green Waste</th> </tr> </thead> <tbody> <tr> <td>2024: 84%</td> <td>2024: 83%</td> <td>2024: 82%</td> <td>2024: 79%</td> </tr> <tr> <td>2023: 78%</td> <td>2023: 77%</td> <td>2023: 75%</td> <td>2023: 58%</td> </tr> <tr> <td>2022: 75%</td> <td>2022: 76%</td> <td>2022: 74%</td> <td>2022: 59%</td> </tr> </tbody> </table>	General Waste	Mixed recycling	Glass	Green Waste	2024: 84%	2024: 83%	2024: 82%	2024: 79%	2023: 78%	2023: 77%	2023: 75%	2023: 58%	2022: 75%	2022: 76%	2022: 74%	2022: 59%
General Waste	Mixed recycling	Glass	Green Waste															
2024: 84%	2024: 83%	2024: 82%	2024: 79%															
2023: 78%	2023: 77%	2023: 75%	2023: 58%															
2022: 75%	2022: 76%	2022: 74%	2022: 59%															
HCC internal capacity	Complete	<ul style="list-style-type: none"> <li>In the context of the 12-month implementation review, HCC undertook a review of its own internal capacity to deliver on the R&amp;R service and the wider waste minimisation work programme.</li> <li>A business case for changes to the HCC Solid Waste Team (making some roles permanent, adding two additional waste minimisation roles) was considered and approved in March 2024. The changes have been implemented. The last role to be filled (resource recovery lead) will join the team on 30 September 2024.</li> </ul>																
Effectiveness of bin latches	Complete	<ul style="list-style-type: none"> <li>In response to bins falling over and spilling their content despite a latch being fitted, HCC conducted a survey of those residents that have been provided with a second latch that can be retrofitted. The feedback suggests that a second bin latch is effective in reducing the risk of bins spilling content, with more than 80% of respondents finding them useful or very useful.</li> <li>Residents can continue to request a second latch via Council's Too Good To Waste portal. However, work is under to make second latches available via Council's hubs to make access easier for residents</li> </ul>																
New potential food and green organic (FOGO) service (HCC in collaboration with Wellington City Council)	Under way	<ul style="list-style-type: none"> <li>HCC approved various funds to enable the implementation of a new FOGO service in 2027 in its LTP (alongside WCC). However, Council also asked officers to carry out further work, as per the below committee minutes:</li> </ul> <div style="border: 1px solid black; padding: 5px;"> <p><b>RECOMMENDED:</b> (Mayor Barry/Cr Briggs) <b>Minute No. LTPAP 24311(2)</b></p> <p><i>"That the Subcommittee recommends that Council:</i></p> <p>(6) <i>approves for inclusion in the final Long Term 2024-2034 the food organics and green organics collection service option 1, however notes that in recognition of the feedback received from our community during the consultation, as well as the uncertainty regarding food and organic participation rates, reliance on unconfirmed government funding, and the need to accommodate those who currently compost, officers have been asked to do further work to identify how these concerns might be met before proceeding further;"</i></p> </div> <ul style="list-style-type: none"> <li>Work to respond to these questions is underway (eg how to accommodate those that currently compost, bin audit), and a report back to Council is scheduled for November 2024.</li> <li>HCC and WCC have signed an agreement with MFE that secures funding toward the roll out of FOGO bins, should implementation go ahead.</li> <li>The next stage of the procurement process (RFP stage) to identify a suitable processing solution is scheduled to commence in October 2024.</li> <li>Once the procurement process has concluded and there is clarity on the future costs of the service, HCC will need to make final decisions on whether to continue with the implementation of the FOGO service. This is tentatively scheduled for mid-2025.</li> <li>Note that in July 2024, PCC opted not to participate in the next procurement process stage, and it declined the offer of MFE funding toward roll-out costs and bins.</li> </ul>																





## **Contract Information USB**

Waste Collection Services

Contract: AD16 - 4405

## **Contract Information USB**

The Contract Information USB has been shared with both parties and contains supporting information for this contract, including:

- The Principal's RFP document
- The Contractor's proposal
- HCC Price Clarifications Waste Management Service Post Meeting
- HCC Non-Price Clarifications Waste Management NZ Ltd
- Tags to Kerbside Collection Contract\_271020
- Legal Review of Kerbside Collections Contract\_271020
- Notice to Respondents #1-#4 and their attachments

2 July 2024 meeting recording publicly available at:

<https://www.youtube.com/watch?v=XkVHWGGAl-s&list=PLGFhMTCHkiWnXvsasCBBC6PRWuMHgeukU&index=20>, discussion on electric truck requirement between 21:14 to 24:10min

**From:** [Geoffrey Roberts](#)  
**To:** [Samihana Khatri](#)  
**Subject:** FW: [EXTERNAL] EV comment  
**Date:** Wednesday, 13 November 2024 8:16:00 am  
**Attachments:** [image001.png](#)  
[HCC Price Clarifications - Waste Management NZ Ltd 08.07.2020.pdf](#)

---

As mentioned – I’m not sure she really addresses the question but I was interested to see the attached doc.

---

**From:** Sarah Whiteman <[swhiteman@wm.nz](mailto:swhiteman@wm.nz)>  
**Sent:** Monday, November 4, 2024 9:38 AM  
**To:** Geoffrey Roberts <[Geoffrey.Roberts@huttcity.govt.nz](mailto:Geoffrey.Roberts@huttcity.govt.nz)>  
**Cc:** Jörn Scherzer <[Joern.Scherzer@huttcity.govt.nz](mailto:Joern.Scherzer@huttcity.govt.nz)>; [REDACTED]  
**Subject:** [EXTERNAL] EV comment

Hi Geoff,

Hope all is well.

I am just following up re a comment that was made about the EV’s to [REDACTED] last week. Hutt City Council is not at a financial disadvantage with the EV’s off the road.

I have attached the HCC price Clarifications document as part of tender negotiations.

One of the questions was:

“If you had not included EVs in your recycling fleet at the start of the contract, would there have been any difference in your price?”

No. Electric vehicles are certainly more expensive than their diesel counterpart. Thanks to our national footprint and EV Innovation Hub we have been able to offer Council the EV collection vehicles at their diesel vehicle equivalent. Application of lower specification diesel or used vehicles would have had the impact of reducing price.

I hope this clears up any confusion.

Ngā Mihi | Kind regards,

**Sarah Whiteman**

Regional Manager – Wellington

WM New Zealand

97-99 Port Road, Seaview, Lower Hutt 5010

M: [REDACTED] E: [swhiteman@wm.nz](mailto:swhiteman@wm.nz)

[www.wm.nz](http://www.wm.nz)

-



This electronic message together with any attachments is confidential. If you are not the intended recipient: (i) do not copy, disclose or use the contents in any way; (ii) please let us know by return e-mail immediately and then permanently delete the message and destroy all printed copies. Waste Management NZ Ltd is not responsible for any changes made to this message and/or any attachments after sending by Waste Management.

**From:** [Geoffrey Roberts](#)  
**To:** [Jörn Scherzer](#)  
**Subject:** FW: Response to Elected Members request | 2024-542 | EV Rubbish Trucks  
**Date:** Thursday, 4 April 2024 11:36:00 am  
**Attachments:** [ATT00001.png](#)  
[ATT00002.png](#)

---

On this one – shall we get Brad to look at this for us? He could tell us what potential remedies there are for breach of contract, it may be that none of them are palatable (triggering the dispute resolution clause etc) but might be good to get this info in case we get further questions on this and what we are doing about it. I can brief Brad if you like?

---

**From:** Jörn Scherzer <[Joern.Scherzer@huttcity.govt.nz](mailto:Joern.Scherzer@huttcity.govt.nz)>  
**Sent:** Wednesday, April 3, 2024 6:17 PM  
**To:** Elected Members Requests <[electedmembersrequests@huttcity.govt.nz](mailto:electedmembersrequests@huttcity.govt.nz)>  
**Cc:** Alison Geddes <[Alison.Geddes@huttcity.govt.nz](mailto:Alison.Geddes@huttcity.govt.nz)>; Geoffrey Roberts <[Geoffrey.Roberts@huttcity.govt.nz](mailto:Geoffrey.Roberts@huttcity.govt.nz)>  
**Subject:** FW: Response to Elected Members request | 2024-542 | EV Rubbish Trucks

Response:

The electrification of trucks is a contractual obligation, but there are no financial penalties associated with it.

**Jörn Scherzer**  
Head Of Climate & Solid Waste

Hutt City Council, 30 Laings Road, Hutt Central, Lower Hutt 5010  
**P: M:** [REDACTED] **W:** [www.huttcity.govt.nz](http://www.huttcity.govt.nz)

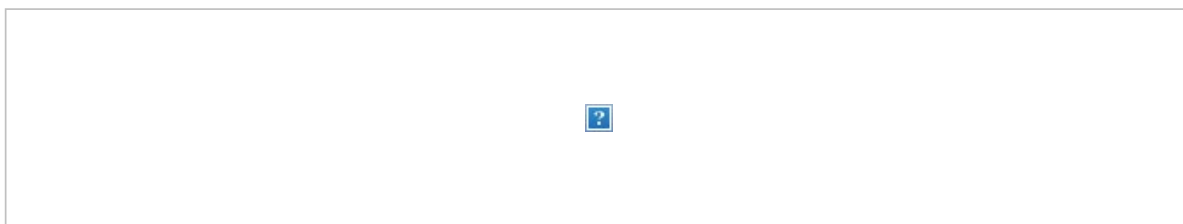

---

**From:** Elected Members Requests <[electedmembersrequests@huttcity.govt.nz](mailto:electedmembersrequests@huttcity.govt.nz)>  
**Sent:** Wednesday, April 3, 2024 1:50 PM  
**To:** Jörn Scherzer <[Joern.Scherzer@huttcity.govt.nz](mailto:Joern.Scherzer@huttcity.govt.nz)>  
**Subject:** FW: Response to Elected Members request | 2024-542 | EV Rubbish Trucks

Kia ora Jörn. Can you provide a response to Cr Mitchell's second question?

---

**From:** Andy Mitchell <[Andy.Mitchell@huttcity.govt.nz](mailto:Andy.Mitchell@huttcity.govt.nz)>  
**Sent:** Friday, March 29, 2024 12:10 AM  
**To:** Elected Members Requests <[electedmembersrequests@huttcity.govt.nz](mailto:electedmembersrequests@huttcity.govt.nz)>  
**Subject:** Re: Response to Elected Members request | 2024-542 | EV Rubbish Trucks

Thanks for this information. Was it a contractual obligation for the electrification of trucks, and are there any penalties for the timeframe not being met?

**Andy Mitchell**

Eastern Ward Councillor

Hutt City Council, [30 Laings Road, Private Bag 31912](#), Lower Hutt 5040, New Zealand

T: [REDACTED] W: [www.huttcity.govt.nz](http://www.huttcity.govt.nz) F: [www.facebook.com/CrAndyMitchell](https://www.facebook.com/CrAndyMitchell)

On 28/03/2024, at 6:07 PM, Elected Members Requests  
<[electedmembersrequests@huttcity.govt.nz](mailto:electedmembersrequests@huttcity.govt.nz)> wrote:

Tēnā koutou katoa,

We received an email from Cr Dyer (see email below).

**The response from Jörn Scherzer, Head of Climate & Solid Waste follows:**

Currently half of all trucks are electric, and some more will be added during this year.

While the intention was to have all trucks fully electric by the end of 2024, the achievement of this target was and is reliant on there being charging stations and associated capacity being available. Waste Management New Zealand's (WMNZ) intention was to have expanded truck charging facilities at their new proposed site in Manor Park, as that site would not only host a new resource recovery park and transfer station, but also new offices and truck maintenance facilities. However, while they submitted the consent application for their proposal for that site in February 2023, it is still going through the consent process, and hence it would not possible to have all collection vehicles electrified until that site is operational. In a best case scenario, and should consent be granted, the site might be operational by the end of 2025.

Having said that, we are working with WM New Zealand on a potential alternative solution. As reported via the Council's Climate Change and Sustainability Committee, work is progressing on a Heavy EV Charging Hub at Silverstream Landfill, with a scheduled completion of Phase 1 by the end of 2024, and Phase 2 by mid-2025. Hence, we are exploring the possibility of whether at least some of the collection vehicles could be charged at Silverstream for an interim period, to enable electrification in line with the original timeline.

Note: it is the Elected Member's responsibility to respond to any residents who have asked questions that you are sending to Elected Members Requests for answers. This email address is to be used by Councillors and Community Board Chairs only, not the public.

Ngā mihi nui,

**Hamish Bell**

Elected Member Support Coordinator

Hutt City Council, 30 Laings Road, Lower Hutt 5010

M: [REDACTED] W: [www.huttcity.govt.nz](http://www.huttcity.govt.nz)

<image001.png>

-----Original Message-----

From: Brady Dyer <[Brady.Dyer@huttcity.govt.nz](mailto:Brady.Dyer@huttcity.govt.nz)>

Sent: Wednesday, March 27, 2024 9:41 PM

To: Elected Members Requests <[electedmembersrequests@huttcity.govt.nz](mailto:electedmembersrequests@huttcity.govt.nz)>

Subject: 2024-542 | EV Rubbish Trucks

Kia ora,

Are all of our collection trucks transitioned to full EV now?

The last comms we saw on the transition was "Collection service will be run with fully electric trucks by 2024" - so just wondering if this has happened?

Ngā mihi,

Brady



PRODUCT NAME <b>SPORT/RECYCLE</b>	DATE 29/05/09	REVISION 03	SHEET 1 OF 1	<b>SD-SL5-0001</b>
PRODUCT CODE	PRODUCT SIZE/CAPACITY 14/18/22/25/29/35m <sup>3</sup>	SALES MARKET <b>DOMESTIC &amp; EXPORT</b>		PRODUCT FUNCTION VARIATION <b>GEN V DECAL AREA DIMENSIONS</b>
BODY OPTIONS				
VEHICLE MAKE		VEHICLE MODEL	AXLE CONFIGURATION	WHEELBASE
CAB/CHASSIS OPTIONS				VCS CODE

## GEN V SIDE LOADER DECAL AREA DIMENSIONS

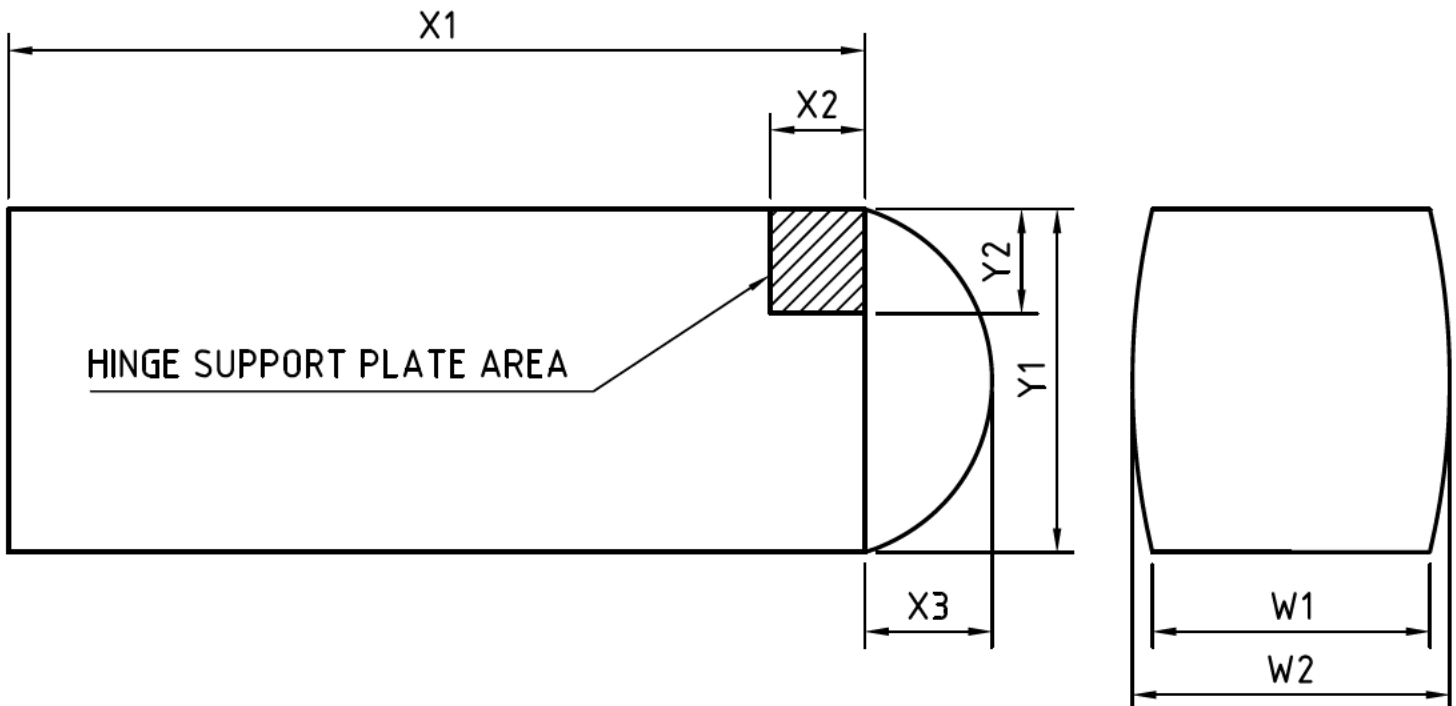

BODY SIZE	X1	Y1	X2	Y2	X3	W1	W2
14m SERIES I	2680	1625	255	285	700	1770	2250
18m SERIES I	3465	1625	255	285	700	1770	2250
22m SERIES I	4550	1625	255	285	700	1770	2250
25m SERIES II	4050	1990	255	285	1000	1800	2280
29m SERIES II	4550	1990	255	285	1000	1800	2280
35m SERIES III	5248	2190	255	285	1000	1800	2280

30 September 2024

Jörn Scherzer  
Head of Climate, Waste and Resource Recovery  
Hutt City Council  
[Joern.Scherzer@huttcity.govt.nz](mailto:Joern.Scherzer@huttcity.govt.nz)>

**RE: Recent recall**

WMNZ wish to advise Hutt City Council of the recent removal of seven Electric Trucks that service the current kerbside waste and recycling contract.

WMNZ became aware of a Health & Safety issue that due to the nature of such required the immediate removal of the Electric Trucks.

We are instigating a legal process with the supplier and will inform Council as and when we can with any outcomes.

Although disappointing, we are completely committed to the safety of our people first and foremost. To date the collections have been unaffected and you can be assured we will work to ensure it remains that way.

Yours sincerely



Sarah Whiteman  
Wellington Regional Manager  
WM New Zealand  
[REDACTED]  
swhiteman@wm.nz



**From:** [Jörn Scherzer](#)  
**To:** [REDACTED]  
**Cc:** [Sarah Whiteman](#)  
**Subject:** RE: [EXTERNAL] EV Sideload  
**Attachments:** [image001.png](#)

---

Great stuff. A number of people in the comms team are already on leave, so I suggest we leave it until January, and by then you may have completed the testing? That will give us more time to plan something, say for end of January?

I am away until 6 Jan, and then away again for the week of 13 to 19 Jan.

Cheers

## Jörn Scherzer

(pronounce as "Yearn Shar-tza)

Head of Climate, Waste and Resource Recovery

Hutt City Council, 30 Laings Road, Private Bag 31912, Lower Hutt 5040, New Zealand

M [REDACTED], W [www.huttcity.govt.nz](http://www.huttcity.govt.nz)

---

**From:** [REDACTED]  
**Sent:** Thursday, December 19, 2024 1:27 PM  
**To:** Jörn Scherzer <Joern.Scherzer@huttcity.govt.nz>  
**Cc:** Sarah Whiteman <swhiteman@wm.nz>  
**Subject:** [EXTERNAL] EV Sideload

Hi Jorn,

Christmas has come early for us and the EV Sideload has arrived and handover has been completed. We are now going to commence testing.

Let us know what you would like to do in regards to communications and photo opportunity?

Kind regards,

[REDACTED]  
Branch Manager – Municipal

WM New Zealand  
97 Port Road, Seaview, Wellington, 5010

M: + [REDACTED] E: [REDACTED]

[www.wm.nz](http://www.wm.nz)

Men in orange jackets standing next to a pipe? ? Description automatically generated



This electronic message together with any attachments is confidential. If you are not the intended

recipient: (i) do not copy, disclose or use the contents in any way; (ii) please let us know by return e-mail immediately and then permanently delete the message and destroy all printed copies. Waste Management NZ Ltd is not responsible for any changes made to this message and/or any attachments after sending by Waste Management.

**From:** [Geoffrey Roberts](#)  
**To:** [Jörn Scherzer](#)  
**Subject:** RE: Response to Elected Members request | 2024-542 | EV Rubbish Trucks  
**Date:** Monday, 8 April 2024 8:04:00 am  
**Attachments:** [image001.png](#)  
[image002.png](#)

---

Have been in touch with Lakna on this and will keep you posted.

If one were to be strict about this, one approach would be to work out the cost of electrifying all the trucks vs status quo and subtract that from the value of the contract. We could ask them for their costings for this as part of their tender.

---

**From:** Jörn Scherzer <Joern.Scherzer@huttcity.govt.nz>  
**Sent:** Thursday, April 4, 2024 11:41 AM  
**To:** Geoffrey Roberts <Geoffrey.Roberts@huttcity.govt.nz>  
**Subject:** RE: Response to Elected Members request | 2024-542 | EV Rubbish Trucks

Yes please, would be good to know

**Jörn Scherzer**  
Head Of Climate & Solid Waste

Hutt City Council, 30 Laings Road, Hutt Central, Lower Hutt 5010

**P:** **M:** [REDACTED] **W:** [www.huttcity.govt.nz](http://www.huttcity.govt.nz)



---

**From:** Geoffrey Roberts <[Geoffrey.Roberts@huttcity.govt.nz](mailto:Geoffrey.Roberts@huttcity.govt.nz)>  
**Sent:** Thursday, April 4, 2024 11:36 AM  
**To:** Jörn Scherzer <[Joern.Scherzer@huttcity.govt.nz](mailto:Joern.Scherzer@huttcity.govt.nz)>  
**Subject:** FW: Response to Elected Members request | 2024-542 | EV Rubbish Trucks

On this one – shall we get Brad to look at this for us? He could tell us what potential remedies there are for breach of contract, it may be that none of them are palatable (triggering the dispute resolution clause etc) but might be good to get this info in case we get further questions on this and what we are doing about it. I can brief Brad if you like?

**Geoffrey Roberts**  
Manager Waste Minimisation

Hutt City Council, 30 Laings Road, Hutt Central, Lower Hutt 5010

**P:** **M:** [REDACTED] **W:** [www.huttcity.govt.nz](http://www.huttcity.govt.nz)



---

**From:** Jörn Scherzer <[Joern.Scherzer@huttcity.govt.nz](mailto:Joern.Scherzer@huttcity.govt.nz)>  
**Sent:** Wednesday, April 3, 2024 6:17 PM  
**To:** Elected Members Requests <[electedmembersrequests@huttcity.govt.nz](mailto:electedmembersrequests@huttcity.govt.nz)>  
**Cc:** Alison Geddes <[Alison.Geddes@huttcity.govt.nz](mailto:Alison.Geddes@huttcity.govt.nz)>; Geoffrey Roberts <[Geoffrey.Roberts@huttcity.govt.nz](mailto:Geoffrey.Roberts@huttcity.govt.nz)>  
**Subject:** FW: Response to Elected Members request | 2024-542 | EV Rubbish Trucks

Response:

The electrification of trucks is a contractual obligation, but there are no financial penalties associated with it.

**Jörn Scherzer**  
Head Of Climate & Solid Waste

Hutt City Council, 30 Laings Road, Hutt Central, Lower Hutt 5010

**P:** **M:** [REDACTED] **W:** [www.huttcity.govt.nz](http://www.huttcity.govt.nz)



---

**From:** Elected Members Requests <[electedmembersrequests@huttcity.govt.nz](mailto:electedmembersrequests@huttcity.govt.nz)>  
**Sent:** Wednesday, April 3, 2024 1:50 PM  
**To:** Jörn Scherzer <[Joern.Scherzer@huttcity.govt.nz](mailto:Joern.Scherzer@huttcity.govt.nz)>  
**Subject:** FW: Response to Elected Members request | 2024-542 | EV Rubbish Trucks

Kia ora Jörn. Can you provide a response to Cr Mitchell's second question?

---

**From:** Andy Mitchell <[Andy.Mitchell@huttcity.govt.nz](mailto:Andy.Mitchell@huttcity.govt.nz)>  
**Sent:** Friday, March 29, 2024 12:10 AM  
**To:** Elected Members Requests <[electedmembersrequests@huttcity.govt.nz](mailto:electedmembersrequests@huttcity.govt.nz)>  
**Subject:** Re: Response to Elected Members request | 2024-542 | EV Rubbish Trucks

Thanks for this information. Was it a contractual obligation for the electrification of trucks, and are there any

penalties for the timeframe not being met?

**Andy Mitchell**

Eastern Ward Councillor

Hutt City Council, [30 Laings Road, Private Bag 31912](#), Lower Hutt 5040, New Zealand

T [REDACTED] W [www.huttcity.govt.nz](http://www.huttcity.govt.nz) F [www.facebook.com/CrAndyMitchell](https://www.facebook.com/CrAndyMitchell)

On 28/03/2024, at 6:07 PM, Elected Members Requests  
<[electedmembersrequests@huttcity.govt.nz](mailto:electedmembersrequests@huttcity.govt.nz)> wrote:

Tēnā koutou katoa,

We received an email from Cr Dyer (see email below).

**The response from Jörn Scherzer, Head of Climate & Solid Waste follows:**

Currently half of all trucks are electric, and some more will be added during this year.

While the intention was to have all trucks fully electric by the end of 2024, the achievement of this target was and is reliant on there being charging stations and associated capacity being available. Waste Management New Zealand's (WMNZ) intention was to have expanded truck charging facilities at their new proposed site in Manor Park, as that site would not only host a new resource recovery park and transfer station, but also new offices and truck maintenance facilities. However, while they submitted the consent application for their proposal for that site in February 2023, it is still going through the consent process, and hence it would not possible to have all collection vehicles electrified until that site is operational. In a best case scenario, and should consent be granted, the site might be operational by the end of 2025.

Having said that, we are working with WM New Zealand on a potential alternative solution. As reported via the Council's Climate Change and Sustainability Committee, work is progressing on a Heavy EV Charging Hub at Silverstream Landfill, with a scheduled completion of Phase 1 by the end of 2024, and Phase 2 by mid-2025. Hence, we are exploring the possibility of whether at least some of the collection vehicles could be charged at Silverstream for an interim period, to enable electrification in line with the original timeline.

Note: it is the Elected Member's responsibility to respond to any residents who have asked questions that you are sending to Elected Members Requests for answers. This email address is to be used by Councillors and Community Board Chairs only, not the public.

Ngā mihi nui,

**Hamish Bell**

Elected Member Support Coordinator

Hutt City Council, 30 Laings Road, Lower Hutt 5010

M: [REDACTED] W: [www.huttcity.govt.nz](http://www.huttcity.govt.nz)

<image001.png>

-----Original Message-----

From: Brady Dyer <[Brady.Dyer@huttcity.govt.nz](mailto:Brady.Dyer@huttcity.govt.nz)>

Sent: Wednesday, March 27, 2024 9:41 PM

To: Elected Members Requests <[electedmembersrequests@huttcity.govt.nz](mailto:electedmembersrequests@huttcity.govt.nz)>

Subject: 2024-542 | EV Rubbish Trucks

Kia ora,

Are all of our collection trucks transitioned to full EV now?

The last comms we saw on the transition was "Collection service will be run with fully electric trucks by 2024" - so just wondering if this has happened?

Ngā mihi,

Brady